

TO FIT TUBE O.D.	COMPONENT #	"A" DIAMETER	"B" DIAMETER	# OF SLOTS
1-3/8" - 2"	UAC0001	2-1/2"	1-1/16"	3
2" - 2-1/4"	UAC0002	3"	1-5/16"	3
2-1/4" - 2-1/2"	UAC0003	3-1/4"	1-9/16"	3
2-1/2" - 2-7/8"	UAC0004	3-1/2"	1-11/16"	4
2-7/8" - 3-1/4"	UAC0005	3-7/8"	2-1/16"	4
3-1/4" - 3-5/8"	UAC0006	4-1/4"	2-7/16"	4
3-5/8" - 4"	UAC0007	4-5/8"	2-13/16"	4
4" - 4-3/8"	UAC0008	5"	3-3/16"	4
4-3/8" - 4-3/4"	UAC0009	5-3/8"	3-5/16"	6
4-3/4" - 5-1/8"	UAC0010	5-3/4"	3-9/16"	6
5-1/8" - 5-1/2"	UAC0011	6-1/8"	4-1/4"	6
5-1/2" - 5-7/8"	UAC0012	6-1/2"	4-11/16"	6
5-7/8" - 6-1/4"	UAC0013	6-7/8"	5-1/16"	6
6-1/4" - 6-5/8"	UAC0014	7-1/4"	5-7/16"	6
6-5/8" - 7-1/8"	UAC0015	7-3/4"	5-13/16"	6
7-1/8" - 7-5/8"	UAC0016	8-1/4"	6-5/16"	8
7-5/8" - 8-1/8"	UAC0017	8-3/4"	6-13/16"	8
8-1/8" - 8-5/8"	UAC0018	9-1/4"	7-5/16"	8
8-5/8" - 9-1/8"	UAC0019	9-3/4"	7-13/16"	8
9-1/8" - 9-5/8"	UAC0020	10-1/4"	8-5/16"	8
9-5/8" - 10-1/8"	UAC0021	10-3/4"	8-13/16"	8

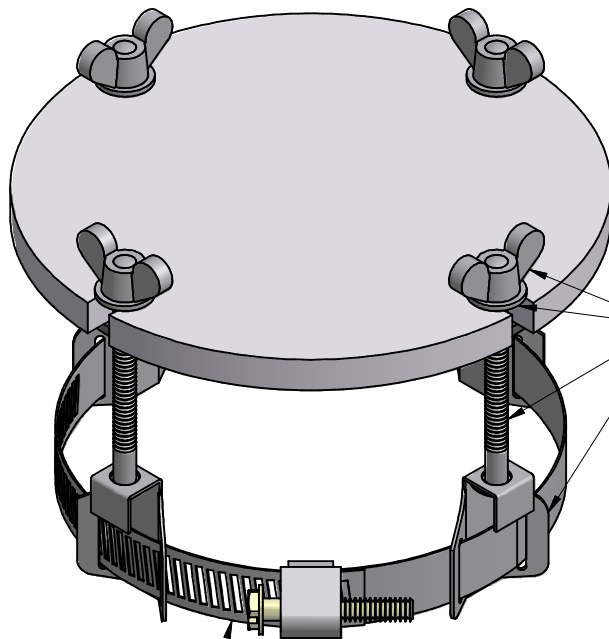
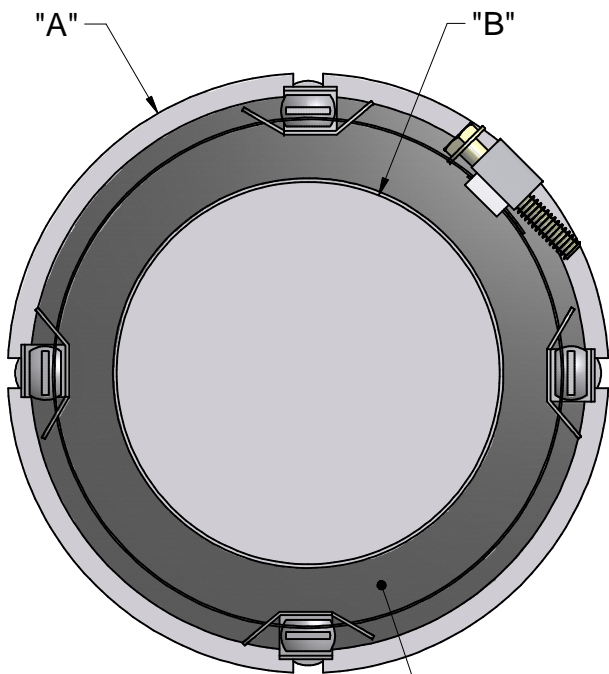

ALUMINUM PLATE = UAP00XX

STAINLESS STEEL FASTENER SET = UFO00XX

VITON GASKET = UGO00XX

STAINLESS STEEL HOSE CLAMP = UCO00XX

NOTE: REPLACES DRAWING M1999211

CONFIDENTIAL: THIS DRAWING IS A CONFIDENTIAL DISCLOSURE OF MCDANEL ADVANCED CERAMIC TECHNOLOGIES. IT MAY NOT BE USED IN ANY MANNER DETRIMENTAL TO MCDANEL ADVANCED CERAMIC TECHNOLOGIES INTERESTS, NOR MAY ANY DISCLOSURE BE MADE TO PARTIES OTHER THAN THOSE TO WHOM THIS DRAWING HAS BEEN ISSUED. COPIES AND REPRODUCTIONS MAY NOT BE MADE WITHOUT WRITTEN PERMISSION.

DRAWN BY: K.L.
 CHECKED BY: J.D.
 CREATION DATE: 5/14/2008
 CHECKED DATE: 5/15/2008

TOLERANCES

0.0..... ± 0.015
 0.00..... ± 0.010
 0.000..... ± 0.005
 FRACTION... ± 1/32
 ANGLES..... ± 1'

DO NOT SCALE
 ALL DIMENSIONS ARE IN INCHES UNLESS NOTED



UNIVERSAL SEAL WITH ALUMINUM PLATE

DWG. UAC00XX REV. -